



Huayu Microinverter (Built-in WiFi) User Manual

- HY-500-Pro
- HY-600-Pro
- HY-600-Pro-127V
- HY-1000-Plus
- HY-1200-Pro
- HY-1300-Pro
- HY-2000-Plus



Huayu(Zhejiang)New Energy Technologies Co.,Ltd.

Add: No.456, Xingning Road, Ningbo 315100, P.R.China

Tel: +86-574-8925 8801

E-mail: info@huayu-energy.com

Website: www.huayu-energy.com

Contents

I . Important Safety Instructions	01
• Safety Instructions	01
• Radio Interference Statement	02
• Product Labels	02
II . Microinverter System Introduction	03
III . Microinverter Introduction	04
IV . Microinverter System Installation	05
• Additional Installation Components	05
• Required Parts and Tools	05
• Installation Procedure	06
V . Microinverter System Operating Instructions	08
VI . Troubleshooting	09
• Status Indication and Error Report	09
• Troubleshooting Procedure	10
VII . Replacement	10
VIII . Technical Data	10
• Microinverter Datasheet (2 in 1)	11
• Microinverter Datasheet (4 in 1)	12
IX . Wiring Diagram	15

I. Important Safety Instructions





This manual contains important instructions for installation and maintenance of full range of Huayu Microinverters. To reduce the risk of electrical shock and ensure safe installation and operation of the Microinverter, the following symbols stand for dangerous conditions and important safety instructions.

Specifications subject to change without notice - please ensure you are using the latest manual found at the manufacturer website: www.huayu-energy.com



Fail to follow these instructions may cause a serious hardware failure or personnel danger.

Safety Instructions

-  **DO NOT** disconnect the PV module from the Microinverter without disconnecting the AC power.
-  Only qualified professionals should install and/or replace the Microinverters.
-  Perform all electrical installations in accordance with local electrical codes.
- ✓ Before installing or using the Microinverter, please read all instructions and cautionary markings in the technical documents and on the Microinverter system and the solar-array.
- ✓ Be aware that the body of the Microinverter is the heat sink and can reach a temperature of 80°C. To reduce risk of burns, do not touch the body of the Microinverter.
-  **DO NOT** attempt to repair the Microinverter. If it fails, contact technical support to obtain an RMA number and start the replacement process. Damaging or opening the Microinverter will void the warranty.

Caution!

The external protective earthing conductor is connected to the inverter protective earthing terminal through AC connector. When connecting, connect the AC connector first to ensure the inverter earthing then do the DC connections. When disconnecting, disconnect the AC by opening the branch circuit breaker first, but maintain the protective earthing conductor in the branch circuit breaker connect to the inverter, then disconnect the DC inputs.

- ✓ In any circumstance, do not connect DC input when AC connector is unplugged.
- ✓ Please install isolation switching devices on the AC side of the inverter.

Radio Interference Statement

CE EMC Compliance: The equipment can comply with CE EMC, which are designed to protect against harmful interference in a residential installation. The equipment could radiate radio frequency energy and this might cause harmful interference to radio communications if not following the instructions when installing and using the equipment. But there is no guarantee that interference will not occur in a particular installation. If this equipment causes harmful interference to radio or television reception, the following measures might resolve the issues:

- 1 Relocate the receiving antenna and keep it well away from the equipment.
- 2 Consult the dealer or an experienced radio/TV technician for help.

Changes or modifications not expressly approved by the party responsible for compliance may void the user's authority to operate the equipment.

Product Labels



Caution, risk of electric shock.



Caution, hot surface.



Symbol for the marking of electrical and electronics devices according to Directive 2002/96/EC. Indicates that the device, accessories and the packaging must not be disposed as unsorted municipal waste and must be collected separately at the end of the usage. Please follow Local Ordinances or Regulations for disposal or contact an authorized representative of the manufacturer for information concerning the decommissioning of equipment.



CE mark is attached to the solar inverter to verify that the unit follows the provisions of the European Low Voltage and EMC Directives.



Refer to the operating instructions.

Qualified Personnel

Person adequately advised or supervised by an electrically skilled person to enable him or her to perceive risks and to avoid hazards which electricity can create. For the purpose of the safety information of this manual, a "qualified person" is someone who is familiar with requirements for safety, refrigeration system and EMC and is authorized to energize, ground and tag equipment, systems, and circuits in accordance with established safety procedures. The inverter may only be commissioned and operated by qualified personnel.

II . Microinverter System Introduction

The Microinverter is used in utility-interactive grid-tied applications, comprised of two key elements:

- Microinverter
- WiFi Router

HY-500-Pro/HY-600-Pro/HY-600-Pro-127V/HY-1000-Plus

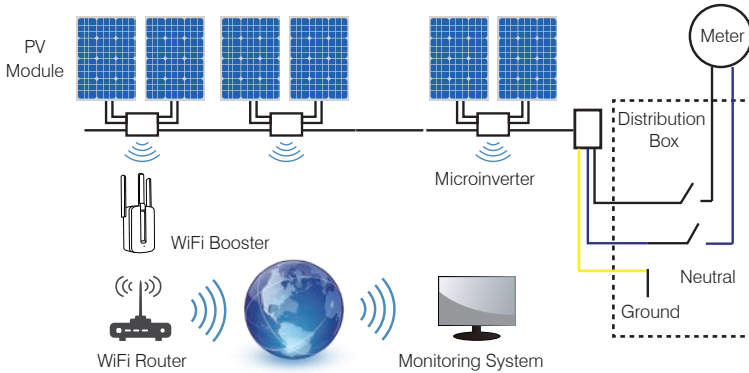

HY-1200-Pro/HY-1300-Pro/HY-2000-Plus

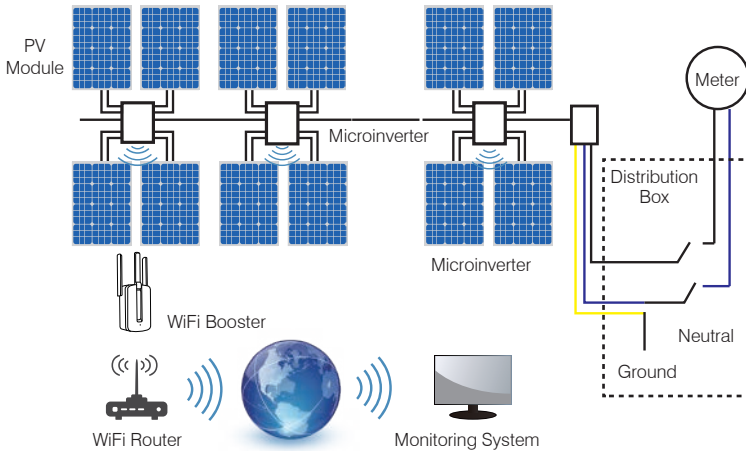

NOTE: If the wireless signal in the area for the Microinverter is weak, it is necessary to add a WiFi signal booster at a suitable place between the router and the microinverter.

This integrated system improves safety; maximizes solar energy harvest; increases system reliability and simplifies solar system design, installation, maintenance and management.

Microinverters Maximize PV Energy Production

Each PV module has individual Maximum Peak Power Tracking (MPPT) controls, which ensures that the maximum power is exported to the utility grid regardless of the performance of the other PV modules in the array. When PV modules in the array are affected by shade, dust, orientation, or any situation in which one module underperforms compared with the other units, the Microinverter ensures top performance from the array by maximizing the performance of each module within the array.

More Reliable than Central Inverter or String Inverter

The distributed Microinverter system ensures that no single point failure exists across the PV system. Microinverters are designed to operate at full power at ambient outdoor temperatures up to 149°F(65°C). The inverter housing is designed for outdoor installation and complies with the IP67 environmental enclosure rating.

Simple to Install

You can install individual PV modules in any combination of Module quantity and orientation, different type and power rate. The Ground wire (PE) of the AC cable is connected to the chassis inside of the Microinverter, potentially eliminating the installation of grounding wire(check local regulation).

Data collection adopts internal WiFi, wireless router is needed near the Microinverter. When complete the installation of microinverter, configure wireless router with internal WiFi(refer to the WiFi user manual). The data will be uploaded automatically. Users can monitor and manage the microinverter through corresponding website or APP.

III . Microinverter Introduction

The Microinverters usually connect with the single-phase grid, but multiple Microinverters in the form of single-phase grid can also achieve three-phase grid, which are matchable with most 60 and 72 cell PV modules. For more information, please see related Technical Data(P11-12).

Model	AC grid	PV Module	Max. Units Per Branch	AC Grid
HY-500-Pro	50/60Hz,230V	60/72 Cell	8 for 25A breaker	MC-4 Type or Customize
HY-600-Pro	50/60Hz,208/220/240V	60/72 Cell	8 for 25A breaker	MC-4 Type or Customize
HY-600-Pro-127V	50/60Hz,127V	60/72 Cell	5 for 25A breaker	MC-4 Type or Customize
HY-1000-Plus	50/60Hz,127V	60/72 Cell	5 for 25A breaker	MC-4 Type or Customize
HY-1200-Pro	50/60Hz,230V	60/72 Cell	4 for 25A breaker	MC-4 Type or Customize
HY-1300-Pro	50/60Hz,208/220/240V	60/72 Cell	4 for 25A breaker	MC-4 Type or Customize
HY-2000-Plus	50/60Hz,208/220/240V	60/72 Cell	4 for 25A breaker	MC-4 Type or Customize

IV. Microinverter System Installation

A PV system by Microinverters is simple to install. Each Microinverter easily mounts on the PV racking system, directly beneath the PV module. Low voltage DC wires connect from the PV module directly to the Microinverter, eliminating the risk of high DC voltage. Installation MUST comply with local regulations and technical rules.

Special Statement! An AC GFCI device should not be used to protect the dedicated circuit to the Microinverter even though it is an outside circuit. None of the small GFCI devices(5--30mA) are designed for back feeding and will be damaged if so. In a similar manner, AC AFCIs have not been evaluated for back feeding and may be damaged if back feed with the output of a PV inverter.



WARNING

Perform all electrical installations in accordance with local electrical codes.

Be aware that only qualified professionals should install and/or replace Microinverters.

Before installing or using a Microinverter, please read all instructions and warnings in the technical documents and on the Microinverter itself as well as on the PV array.

Be aware that installation of this equipment includes the risk of electric shock.

Do not touch any live parts in the system, including the PV array, when the system has been connected to the electrical grid.

Strongly recommend to install surge protection devices in the dedicated combiner box.

Additional Installation Components

- ① AC Male and Female Interconnection Connectors(offered separately)
- ② Sealing end caps(offered separately)

Required Parts and Tools

In addition to your PV array and its associated hardware, the following items are needed for installation:

- ① An AC connection junction box
- ② Mounting hardware suitable for module racking system
- ③ Sockets and wrenches for mounting hardware
- ④ Continuous grounding conductor and grounding washers
- ⑤ A Phillips screwdriver
- ⑥ A torque wrench

Installation Procedure

Step 1- Install AC branch circuit junction box

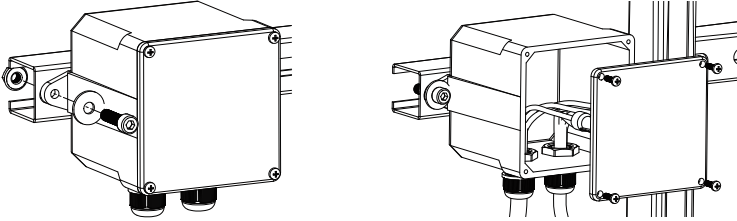

- 1 Install an appropriate junction box at a suitable location on the PV racking system (typically at the end of a branch of modules).
- 2 Connect the open wire end of the AC cable into the junction box using an appropriate gland or strain relief fitting.
- 3 Wire the conductors of the AC (127/220/230): L - red; N - black; PE - yellow green. Wire the conductors of the AC (208/240): L1- red; L2 - black; PE - yellow green.
- 4 Connect the AC branch circuit junction box to the point of utility Interconnection.



WARNING

Wiring colour code can be different according to local regulation, check all the wires of the installation before connecting them to the AC cable. Wrong cabling can damage irreparably Microinverters, such an issue is not covered by the warranty.

Step 2- Attach Microinverters to racking system or the PV module frame

- 1 Mark the location of the Microinverter on the rack, with respect to the PV module junction box or any other obstructions.
- 2 Mount one Microinverter at each of these locations by recommended hardware.

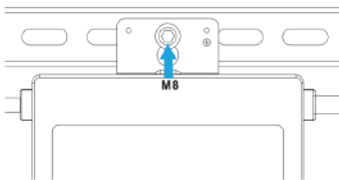

HY-500-Pro / HY-600-Pro(-127V) / HY-1000-Plus

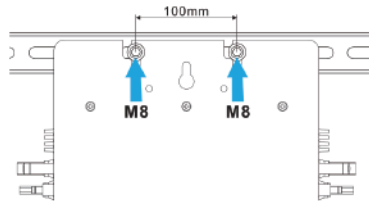

HY-1200-Pro / HY-1300-Pro / HY-2000-Plus



WARNING

Prior to installing any of Microinverters, verify that the utility voltage at the point of common connection matches the voltage rating on Microinverter label.

Do not place the Microinverter (including DC and AC connectors) where exposed to the sun, rain or snow, even gap between modules. Allow a minimum of 3/4 inch (2cm) between roof and bottom of the Microinverter to allow proper air flow.

Step 3- Create an Installation Map

Create a paper installation map to record microinverter serial numbers and position in the array.

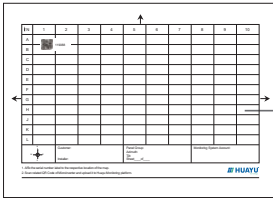

Affix serial number labels

- 1 Peel the removable serial number label from each microinverter and affix it to the respective location on the paper installation map.
- 2 Fill in the monitoring system account information to the installation map
- 3 Always keep a copy of the installation map for your records.

Step 4- Connect the Microinverters in parallel



HY-500-Pro / HY-600-Pro(-127V) / HY-1000-Plus
connected in parallel

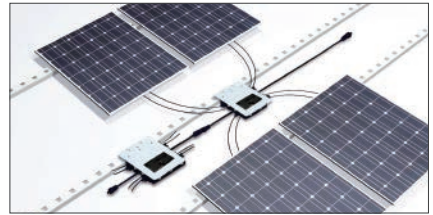

HY-1200-Pro / HY-1300-Pro / HY-2000-Plus
connected in parallel

- 1 Check Microinverter technical data for the maximum allowable number of Microinverters on each AC branch circuit.
- 2 Plug the male AC connector of Microinverter into the female connector to get it connected. AC connector interface is as follows.

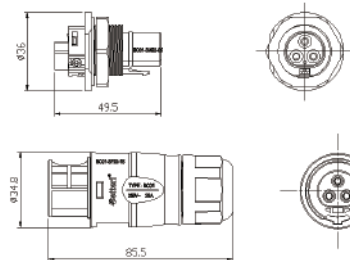
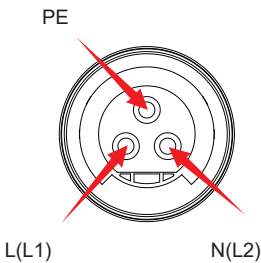

WARNING

DO NOT exceed maximum number of Microinverters in an AC branch circuit.

Step 5- Install an AC cable protective end cap at the end of AC cable

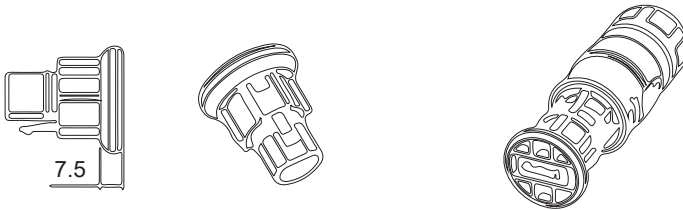

Step 6- Connect Microinverter to PV Modules

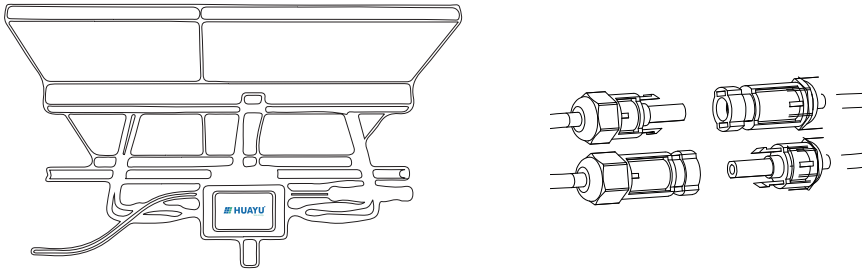

NOTE: When plugging in the DC cable, if AC is already available, the Microinverter should immediately blink red light and will start working within the setting time (default 60 seconds). If AC is not available, the red light will blink 3 times quickly until AC is connected.

V. Microinverter System Operating Instructions

To operate the Microinverter PV system:

- 1 Turn ON the AC circuit breaker on each Microinverter AC branch circuit.
- 2 Turn ON the main utility-grid AC circuit breaker. Your system will start producing power after one minute.
- 3 The units should start blinking red one minute after turning on the AC circuit breaker, then blue LED blinking, it means they are producing power normally, the faster blinking of the blue LED, the more power generated.
- 4 Configure the internal WiFi module according to its user manual.
- 5 Microinverter will start to send performance data over WiFi module to the network every 5 minutes. It enables customers to monitor performance data of each Microinverter through website and APP.

NOTE: When AC power is applied but Microinverter is not started up, about 0.1A current and 25VA(W) power for each Microinverter may be measured by a power meter, this power is reactive power, not from grid.

VI. Troubleshooting

Qualified personnel may follow troubleshooting steps if PV system does not operate correctly.

Status Indication and Error Report

Startup LED

One minute after DC power is first applied to the Microinverter, one short red blink indicates a successful Microinverter startup, greater than two short red blinks after DC power indicates a failure of microinverter setup.

Operation LED

Flashing Blue - Slow	- Producing low power
Flashing Blue - Fast	- Producing high power
Flashing Red	- No power
Red blinking two times	- AC low-voltage or high-voltage
Red blinking three times	- Grid failure

GFDI Error

A four time red LED flashig indicates that Microinverter has detected a Ground Fault Detector Interrupter(GFDI) error in PV system. Unless the GFDI error has been cleared, the LED will remain four times blinking.

Other Faults

All other faults can be reported to the website and APP.



WARNING

Never disconnect the DC wire connectors under load. Ensure that no current is flowing in the DC wires prior to disconnecting. An opaque covering may be used to cover the module prior to disconnecting the module.

There are two possible overall areas of trouble

- 1 The Microinverter itself may be having problems.
- 2 The Microinverter itself is working fine but communication between Microinverter and network gets a problem. The items below refer to Microinverter issues, not communication issues:

A quick way to tell with problems

- 1 Diagnosis from the Microinverter:
 - a) A red light-either blinking or solid on Microinverter or no light at all: means it is definitely the Microinverter problem.
 - b) 0 watts or 2 watts: Means a possible Microinverter problem.
- 2 Diagnosis from network:
 - a) No-Data-Display: The website and APP don't display any data. Check the network configuration.
 - b) Display shows Microinverter is online but there is no data: This could be caused by the issue that server is updating.

Troubleshooting Procedure

- 1 Verify the utility voltage and frequency are within ranges shown in Microinverter Technical Data.
- 2 Check the connection to the grid. Disconnect AC first, then disconnect DC and make sure the grid voltage can be measured at AC connector. Never disconnect the DC wires while a microinverter is producing power. Reconnect the DC module connectors and watch for three short LED flashes.
- 3 Check AC branch circuit interconnection between all Microinverters. Verify each Microinverters inverter is energized by the grid as described in the previous step.
- 4 Make sure that any AC breaker are functioning properly and closed.
- 5 Check the DC connections between Microinverter and PV module.
- 6 Verify PV module DC voltage is within the allowable range shown in Microinverter Technical Data.
- 7 If the problem still persists, please contact a related technical support engineer.



Do not attempt to repair the Microinverter. If troubleshooting methods fail, please call a related technical support engineer.

VII. Replacement

Follow the procedure to replace a failed Microinverter

- 1 Disconnect the Microinverter from the PV Module in the order shown below:
 - a) Disconnect the AC by turning off the branch circuit breaker.
 - b) Disconnect the AC connector of the Microinverter.
 - c) Cover the module with an opaque cover.
 - d) Disconnect the PV module DC wire connectors from the Microinverter.
 - e) Remove the Microinverter from the PV array racking system.
- 2 Remove the opaque cover and install a replaced Microinverter to the bracket. Remember to observe the flashing LED light as soon as the new Microinverter is plugged into the DC cables.
- 3 Connect the AC cable of the replacement Microinverter.
- 4 Close the branch circuit breaker, and verify operation of the replacement Microinverter.

VIII. Technical Data



Voltage and current of PV module should match with those of Microinverter.

DC operating voltage range of PV module should match with the allowable input voltage range of Microinverter.

Maximum open circuit voltage(VOC) of the PV module should not exceed maximum input voltage of Microinverter.

Microinverter Datasheet (2 in 1)

Model	HY-500-Pro	HY-600-Pro	HY-600-Pro-127V
Input Data (DC)			
Recommended input power(STC)	210~400W(2 Pieces)		210~350W
Max.input DC voltage	60V		60V
MPPT Voltage Range	25~55V		25~55V
Operating DC Voltage Range	20~60V		20~60V
Max.DC short circuit current	13A		13A
Max.input current	10.4×2		10.4×2
Output Data (AC)			
Max.Continuous output power	600W		500W
Max.output Current	2.17A	2.884A/2.5A/2.7A	4A
Nominal voltage / range	184~265V	183~229V/211~264V/176~242V	95~155V
Nominal frequency / range	50/47.5~51.5Hz	60/59.3~60.5Hz	60/59.3~60.5Hz
Extended frequency / range	50/45~55Hz	60/55~65Hz	60/55~65Hz
Power factor	>0.95		>0.95
Max.units per branch	8		5
Efficiency			
CEC weighted efficiency	95%		
Peak inverter efficiency	96.5%		
Static MPPT efficiency	99%		
Night time power consumption	50mW		
Mechanical Data			
Ambient temperature range	-40°C ~ +65 °C		
Dimensions(W×H×Dmm)	185×161×29(Without mounting bracket and cable)		
Weight (kG)	2.2kG		
Cooling	Natural Convection - No Fans		
Enclosure environmental rating	IP67		
Features			
Compatibility	Compatible with 60/72 cell PV modules		
Communication	Power Line / WiFi / Zigbee		
Compliance	UL1741,VDE0126,VDE4105,IEC62109,CE,INMETRO		
Warranty	25 Years		

Microinverter Datasheet (2 in 1)

Model	HY-1000-Plus
Input Data (DC)	
Recommended input power(STC)	210-530W
Startup voltage	22V
Max.input DC voltage	60V
MPPT Voltage Range	25~55V
Operating DC Voltage Range	20~60V
Max.DC Short circuit current	15A×2
Max.input Current	12A×2
Output Data (AC)	
Max.Continuous output power	880W
Max.output Current	3.82A
Nominal voltage / range	185-265V
Nominal frequency / range	45-65Hz
Extended frequency / range	60.0/55~65Hz
Power factor	>0.95
Max.units per branch	
Efficiency	
CEC weighted efficiency	95.5%
Peak inverter efficiency	96.4%
Static MPPT efficiency	99.5%
Night time power consumption	0.05mW
Mechanical Data	
Ambient temperature range	-40°C ~ +65°C
Dimensions(W×H×Dmm)	185 × 161 × 29 mm
Weight (kg)	2.4kg
Cooling	Natural Convection - No Fans
Enclosure environmental rating	IP67
Features	
Compatibility	Compatible with 60/72 cell PV modules
Communication	Power Line / WiFi / Zigbee
Compliance	UL1741, INMETRO, VDE0126 ,VDE4105, IEC62109, CE etc.
Warranty	25 Years

Microinverter Datasheet (4 in 1)

Model	HY-1200-Pro	HY-1300-Pro
Input Data (DC)		
Recommended input power(STC)	210~400W(4 Pieces)	
Max.input DC voltage	60V	
MPPT Voltage Range	25~55V	
Operating DC Voltage Range	20~60V	
Max.DC short circuit current	13A/14A	
Max.input current	10.4×4	
Output Data (AC)		
Max.Continuous output power	1300W	
Max.output Current	4.34A	6.25A / 5.416A /5.91A
Nominal voltage / range	184~265V	183~229V / 211~264V/ 176-242V
Nominal frequency / range	50/47.5~51.5Hz	60/59.3~60.5Hz
Extended frequency / range	50/45~55Hz	60/55~65Hz
Power factor	>0.95	
Max.units per branch	4	
Efficiency		
CEC weighted efficiency	95%	
Peak inverter efficiency	96.5%	
Static MPPT efficiency	99%	
Night time power consumption	50mW	
Mechanical Data		
Ambient temperature range	-40°C ~ +65°C	
Dimensions(W×H×Dmm)	287×298.5×36(Without mounting bracket and cable)	
Weight (kG)	6.3kG	
Cooling	Natural Convection - No Fans	
Enclosure environmental rating	IP67	
Features		
Compatibility	Compatible with 60/72 cell PV modules	
Communication	Power Line / WiFi / Zigbee	
Compliance	UL1741,VDE0126,VDE4105,IEC62109,CE,INMETRO	
Warranty	25 Years	

Microinverter Datasheet (4 in 1)

Model	HY-2000-Plus
Input Data (DC)	
Recommended input power(STC)	210-530W
Startup voltage	22V
Max.input DC voltage	60V
MPPT Voltage Range	25~55V
Operating DC Voltage Range	20~60V
Max.DC Short circuit current	15A×2
Max.input Current	12A×4
Output Data (AC)	
Max.Continuous output power	1980W
Max.output Current	8.6A
Nominal voltage / range	185-265V
Nominal frequency / range	45-65Hz
Extended frequency / range	60.0/55~65Hz
Power factor	>0.95
Max.units per branch	
Efficiency	
CEC weighted efficiency	95.5%
Peak inverter efficiency	96.4%
Static MPPT efficiency	99.5%
Night time power consumption	0.05mW
Mechanical Data	
Ambient temperature range	-40°C ~ +65°C
Dimensions(W×H×Dmm)	287 × 298.5 × 36 mm
Weight (kG)	6.3kG
Cooling	Natural Convection - No Fans
Enclosure environmental rating	IP67
Features	
Compatibility	Compatible with 60/72 cell PV modules
Communication	Power Line / WiFi / Zigbee
Compliance	UL1741, INMETRO, VDE0126 ,VDE4105, IEC62109, CE etc.
Warranty	25 Years

IX. Wiring Diagram

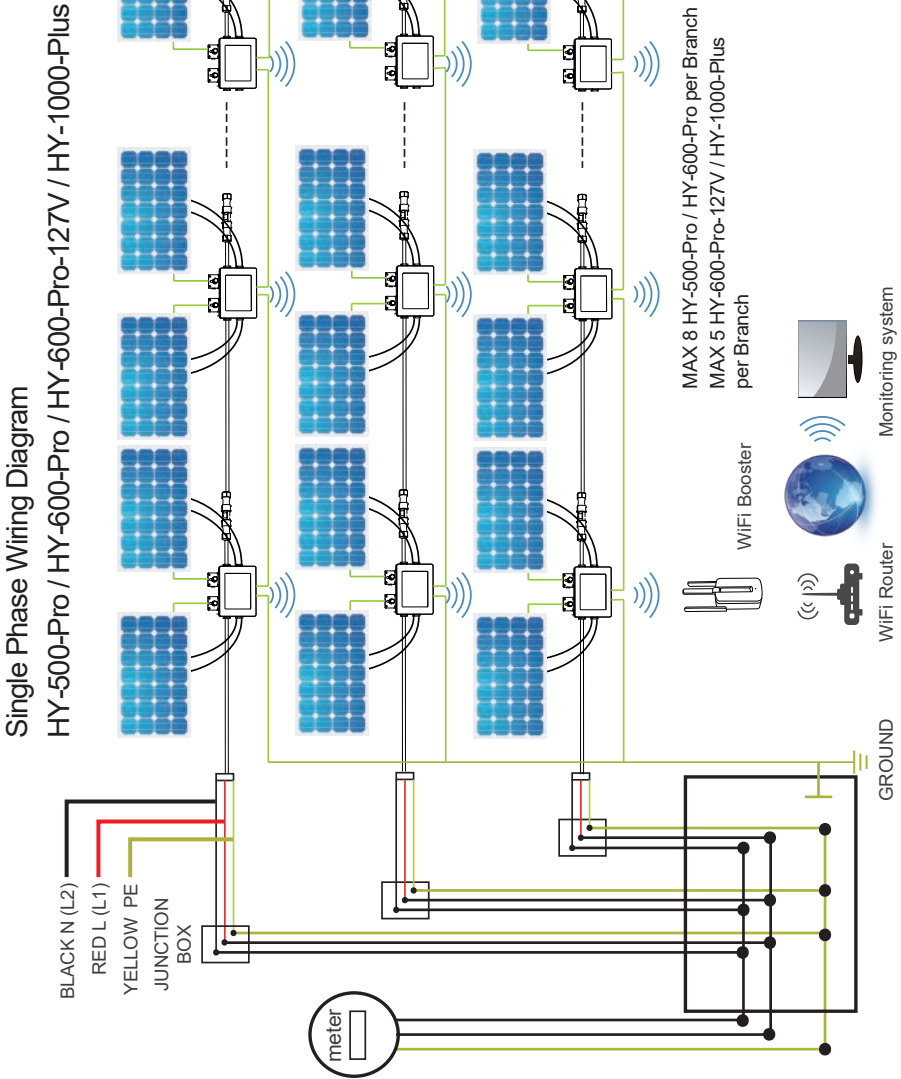

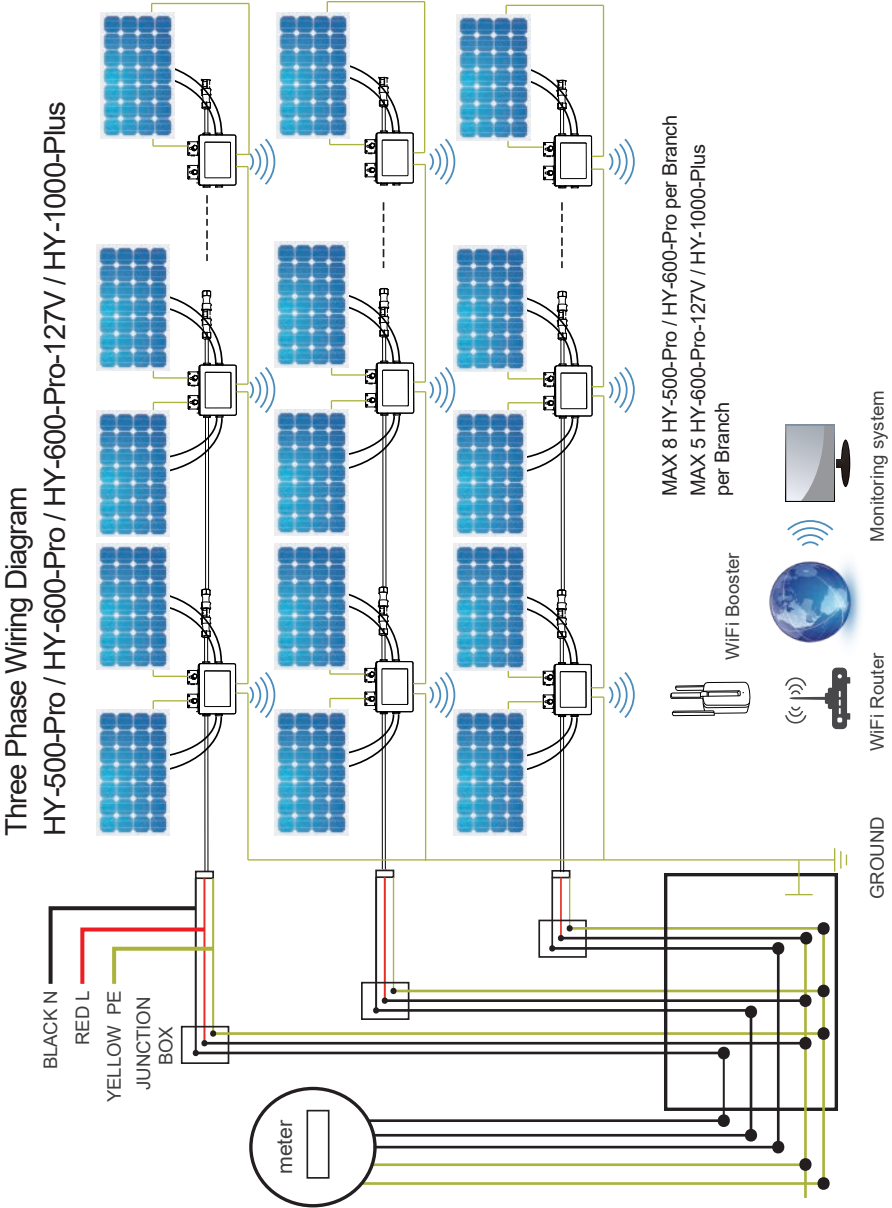

Three Phase Wiring Diagram for North America HY-600-Pro / HY-1000-Plus

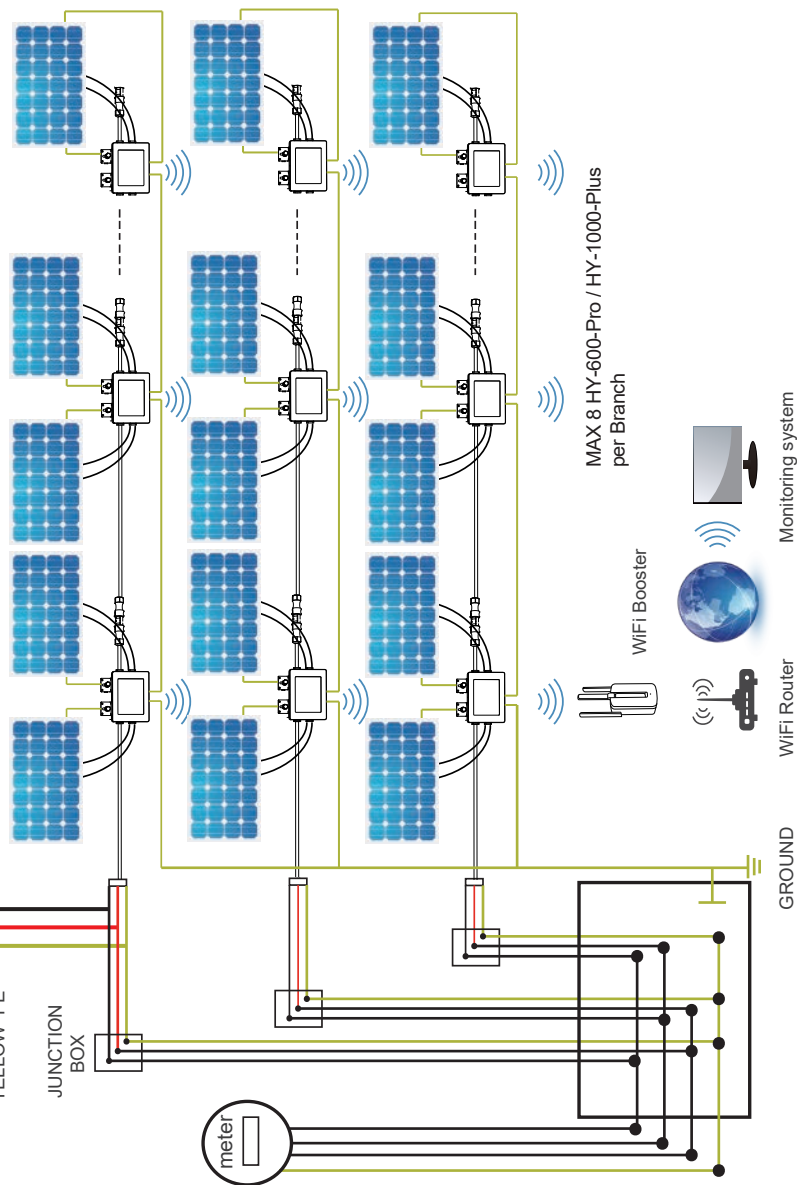

Single Phase Wiring Diagram HY-1200-Pro / HY-1300-Pro / HY-2000-Plus

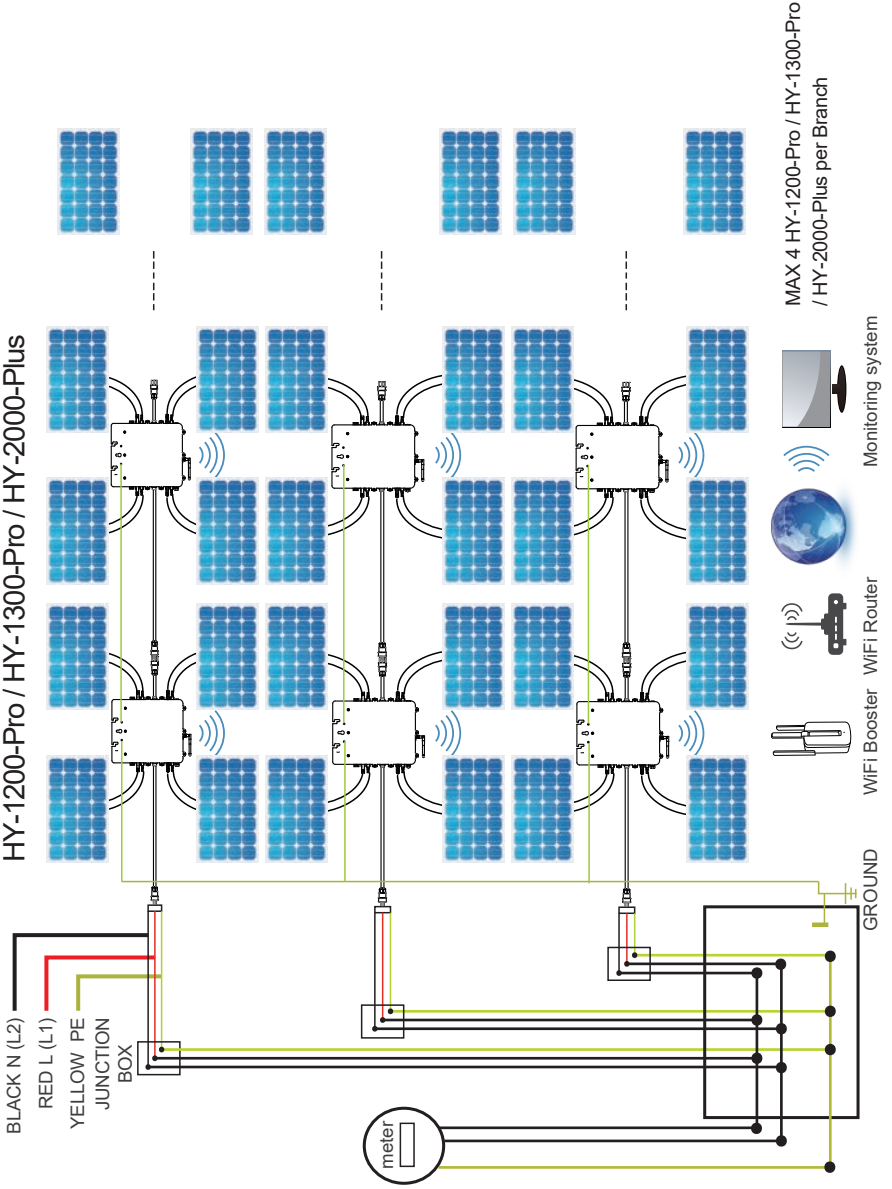

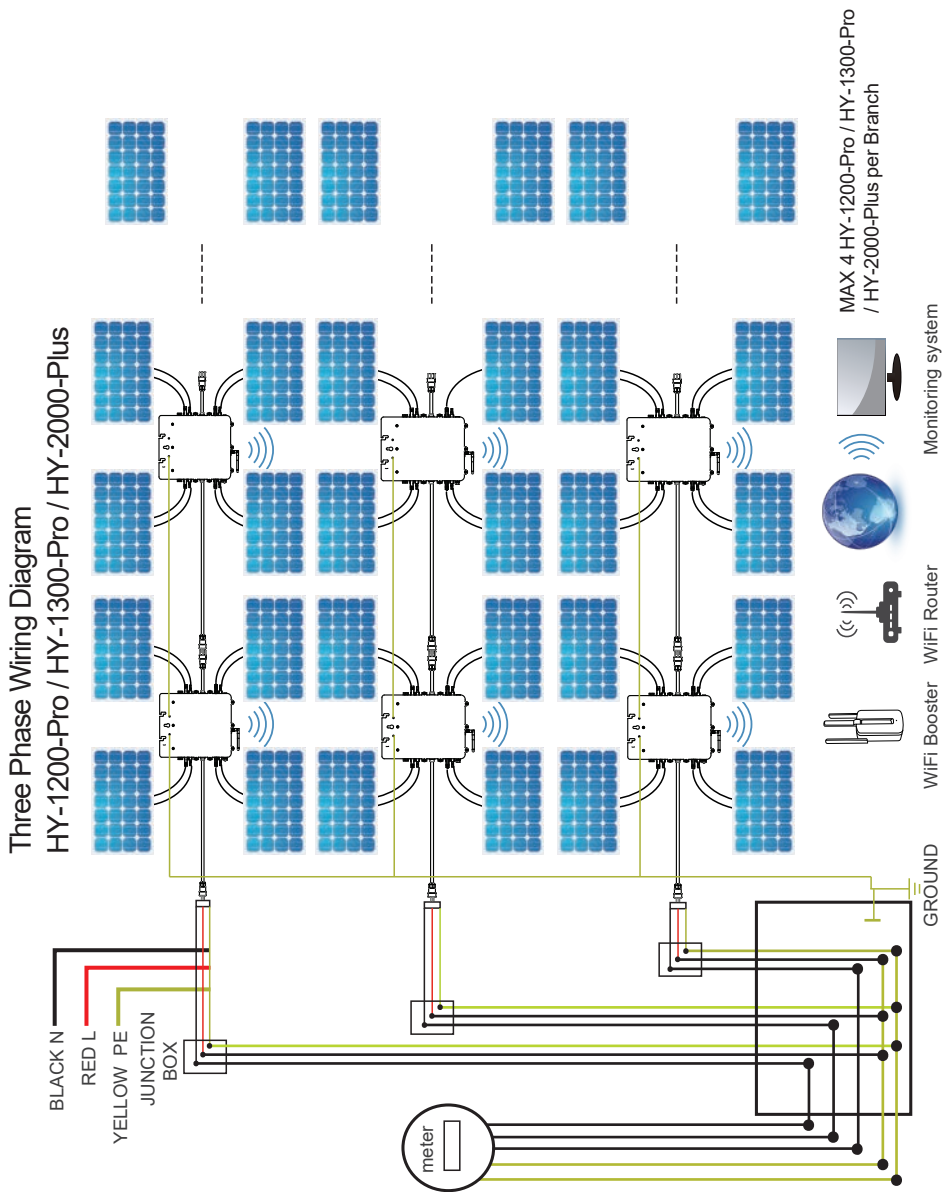

Three Phase Wiring Diagram for North America HY-1300-Pro / HY-2000-Plus

